

Work. Play. Love.

Fast and Fun Ways to Find Joy on the Job
And Inspire Others to Do the Same



LEE SILBER

leesilber@leesilber.com





BACK TO THE FUTURE

We're Going Back to the Year 1990



1990

What was happening 25 years ago?

A close-up portrait of Keith Richards, an elderly man with a weathered face and a wide-brimmed hat. He is looking slightly to the right with a thoughtful expression. The text is overlaid on the lower half of his face.

Keith Richards did turn 74 in 1990 . . .

"I'D RATHER BE DEAD THAN PLAYING 'SATISFACTION' WHEN I'M 50" —HE'S 71

1990

The Year This Association Was First Founded





2015

In the past 25 years a lot has changed.



Pediatric Nurse cleverly disguised a Superhero

We do what we do because we
have to. People need us.
We've been given the power to do
something—it's our gift—the
reason we are here.

W O N D E R W O M A N T O S U P E R M A N

- **“Nurses are stretched in a hundred different directions or we are get so wrapped up in our work we get tunnel vision—either way, we need to find time to be kind to each other.”**

—STEPHANIE BRADY, RN, BSN, CPN



**Pediatric Nurses,
just like regular people,
only nicer.**

WHAT I'VE BEEN TOLD

YOUR JOB

Take This Job and . . .



LET GO

Let Go Of Unrealistic Expectations

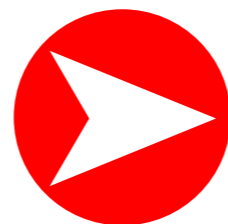

It's called work because all
of the other four-letter
words were taken.

U N K N O W N

When you love your job, you
add five days to every week.

H. J A C K S O N B R O W N E

**Our study showed happy people
are much more productive.**

F A S T C O M P A N Y

It's not always possible to do what
you love, but it is possible to find
ways to love what you do.

LEE SILBER

Turn the job you have
into the job you want.

LEE SILBER



HAPPY?

Happiness is . . .

Happiness is an attitude.
We either make ourselves
miserable, or happy.

FRANCESCA REIGLER

If I can wake up every day and know I won't have to serve anyone food or drinks, I will be happy.

WHICH FORMER "IDOL" SAID IT?

UNHAPPY?

- Don't feel their ideas and input are valued
- Don't feel challenged and their talents are wasted
- Don't feel appreciated or respected

* From a new Gallup Poll about the best and worst places to work conducted in 2014.

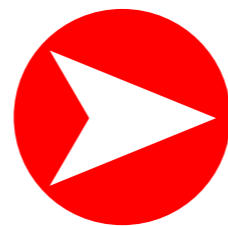

If you won millions of dollars
in the lottery, would you still
show up for work?

LEE SILBER

Your money or your life?
You don't pay for things with
money, you pay for them
with your life.

VICKI ROBIN

- Let's say we make \$50 an hour
- We purchase a pair of shoes for \$200
- Those shoes actually cost us four hours of our life



MONEY

How Much Do You Need To Make To Be Happy?

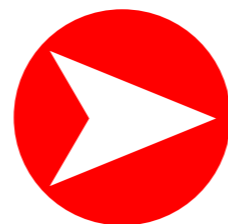



AS SOON AS

I'll be happy as soon as . . .

It's doesn't pay to keep
up with the Joneses.

LEE SILBER

**When we get too busy it's easy
to overlook the obvious.**

LEE SILBER

FedEx®



HAPPY HOUR

Take pictures of the things that make you happy.



NO U DITN'T

If you have a job without
any aggravations, you don't
have a job.

MALCOLM FORBES

**LOVE IT
HATE IT**

The Work Remains The Same



Time flies when you're doing
something you enjoy.

E I N S T E I N

**Stress and anxiety spread because
people pick up on negativity
like second hand smoke.**

U N K N O W N

IT'S NOT ABOUT THE MONEY

People want to feel appreciated, respected,
valued, included, remembered, listened to . . .

**“I’VE LEARNED THAT
PEOPLE WILL FORGET
WHAT YOU SAID,
PEOPLE WILL FORGET
WHAT YOU DID,
BUT PEOPLE WILL
NEVER FORGET HOW
YOU MADE THEM FEEL.”**
MAYA ANGELOU



**People don't care how much you
know until they know how much
you care about them.**

Z I G Z I G L A R

Stephanie Brady

BEST SUPPORTING ACTRESS STARRING IN
"THE MEETING PLANNER" (A DRAMA?)



**Make sure everybody counts and
they know that they count.**

LEE SILBER

**Acknowledge even the
smallest achievements.**

LEE SILBER

MEREDITH WHITNEY

Made Forbes List of 50
Most Powerful Women



I know this sounds silly, but I didn't get any recognition at my firm—not even a pizza party.

M E R E D I T H W H I T N E Y

IN CASE YOU DIDN'T KNOW

You Are Awesome

Here's why you rock!





**WHAT'S IN
A NAME?**

It's a small thing that makes a big difference.

Find small ways to create
memorable moments.

LEE SILBER



THANK YOU

Two words with so much power

The message being sent today is
“We don't care about you”.

U S A T O D A Y

**Keep the people who hate you
away from the people who
are undecided.**

CASEY STENGEL

HAPPY TO BE HERE

I used to give over 100 speeches a year,
but I have become more selective
after a life-changing event

Don't miss your life.

VALERIE HARPER

Today, balance is about living in
the moment and being fully
engaged in what you are doing,
whether at work or at home.

LEE SILBER



LET IT GO

Will it really matter in a month?

**We do not own people or their
thoughts. We can only influence
others by our example . . .
both good and bad.**

JIMMY BUFFETT

Walk The Talk

SET A GOOD EXAMPLE TO FOLLOW





**IT'S NOT
YOU**

We can't change people . . .

**Don't criticize, condemn,
or complain.**

DALE CARNEGIE

**Positive thinking will help you do
anything better than negative
thinking will.**

Z I G Z I G L A R

**Pew! Pew! Pew! That's the sound
of me deflecting your whining
with my happiness shield.**

U N K N O W N

**Hanging onto resentment is
letting someone you despise
live rent-free in your head.**

A N N L A N D E R S

**Be the change you want to
see in the world.**

G A N D H I



RIPPLE

For every action there is a reaction—a Ripple Effect.

What you put out you get back.

O P R A H



SMILE TEST

Smile and the world smiles with you.

**You can have everything
you want if you will just help
enough other people get
what they want.**

Z I G Z I G L A R



Appreciate our differences.

LEE SILBER

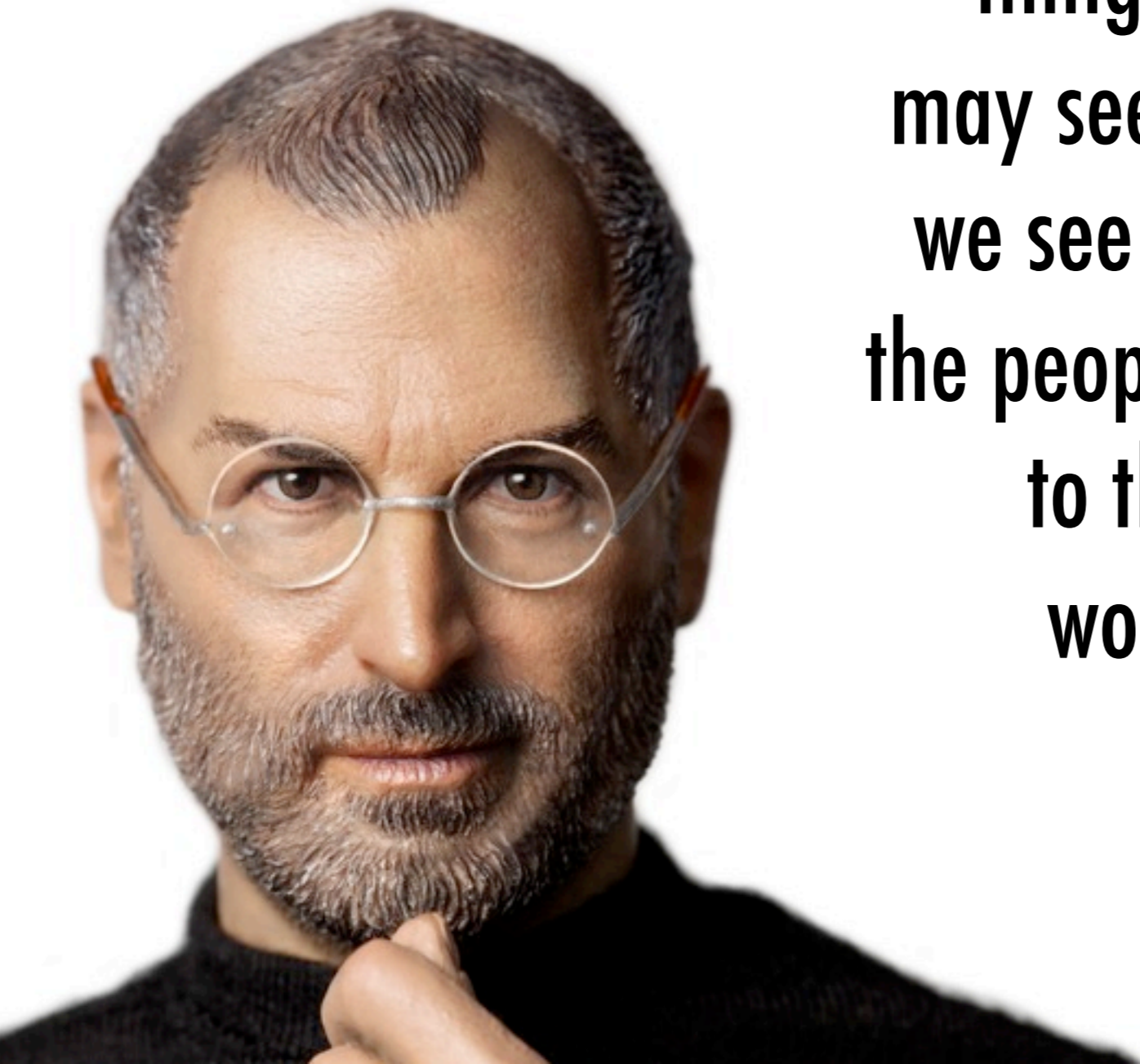

**Here's to the crazy ones.
The misfits. The rebels. The
troublemakers. The ones who see
things differently. While some
may see them as the crazy ones,
we see them as genius. Because
the people who are crazy enough
to think they can change the
world, are the ones who do.**

—STEVE JOBS



GEN WE

Focusing on what we all have in common

BORN 1980 - 2000

Generation Y Millennials

As a product of playdates, positive reinforcement, diversity, abundance, and technology, they collaborate, communicate, and expect good things to happen quickly.



Mark Zuckerberg

Born 1984

BORN 1965 - 1979

Generation X

They are the “Latch-Key” generation so they are comfortable working alone and making up their own rules. They embrace technology (98% use Facebook) but still value tangible things—they will print out manuals.



Kurt Cobain

Born 1967

BORN 1946 - 1964

Baby Boomer Generation

The first "Me" generation and a group that believes they deserve it all. They judge success based on status, and respect others for their past accomplishments.



Oprah Winfrey

Born 1954

BORN BEFORE 1946

The Greatest Generation

They long for the past and find comfort in repetition and routine. They believe in structure, rules, and tradition. They revisit old ideas to come up with "new" ones.



Jackie Robinson

Born 1919

If you have time to complain about something then you have the time to do something about it.

A N T H O N Y J . D ' A N G E L O



ATTENTION

Focus everyone's attention on finding solutions

"The little details are by far the most important."

SHERLOCK HOLMES, SPN MEMBER SINCE 1990

nursing

11-6

Observant

PEDIATRIC

I was lucky to notice
what others didn't.

A L B E R T E I N S T E I N



**THINK
QUICK**

Who is the most innovative person you can think of?

- Kick start your brain by doing something new.
- Focus on what you love, no matter what it is.
- Be obsessed with making things better.
- Be enthusiastic about what you do.
- Create insanely great experiences.
- Pay attention to the details.



THINK

All geniuses use one of these to capture ideas.

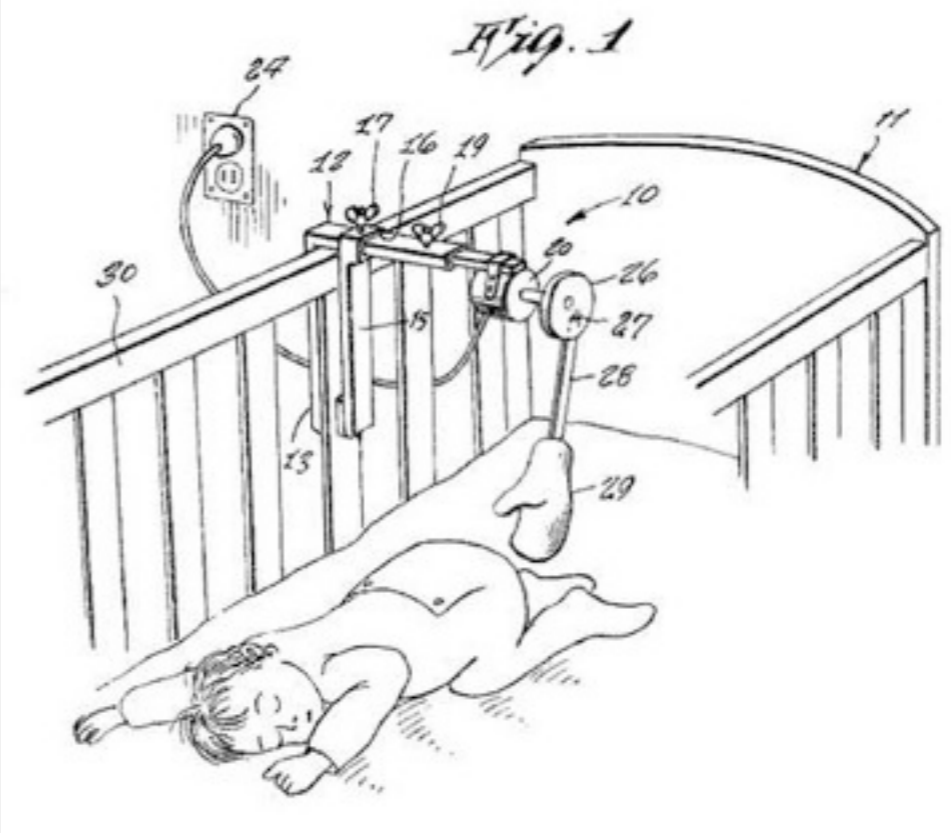
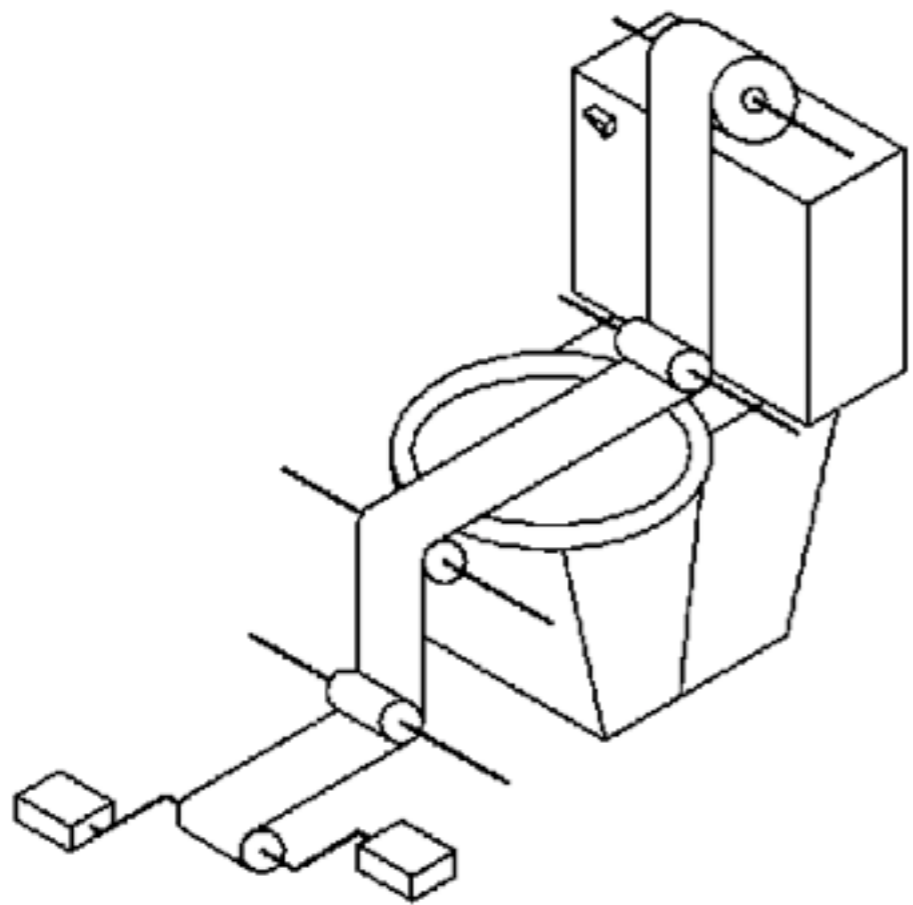

At times we can feel powerless,
but the truth is we have powers we
haven't even tapped into yet.

LEE SILBER



THINK BIG

Start small. Focus on doing the little things well . . . like

Great things are not done by
impulse, but by a series of small
things brought together.

V I N C E N T V A N G O G H

**Accept what you can't change,
and pursue what you can
with all you've got.**

J O H N O ' L E A R Y



PRACTICE

Engage people to practice problem solving





LEFTY

Your right brain is connected to your left hand



Write or doodle with your non-dominant hand



PARTNER

Two heads are often better than one

Resourcefulness is
a sign of genius.

LEE SILBER

We hire great people with a
passion for serving others and
give them the freedom to find
creative ways to take care
of our customers

S O U T H W E S T A I R L I N E S

Southwest Airlines is number
one in every category that counts
when it comes to air travel

J.D. POWERS



**The best ideas can come from
the frontline workers.**

U N D E R C O V E R B O S S

A Starbucks employee in a green apron is holding a Starbucks coffee cup and a straw. The employee is standing behind a window. In the background, there is a view of a blue sky with clouds and a stack of US dollar bills on a windowsill. The text "Starbucks / Ideas Welcome Here" is overlaid on the image.

Starbucks / Ideas Welcome Here



**SMARTY
PANTS?**

Don't be a know it all—let others shine

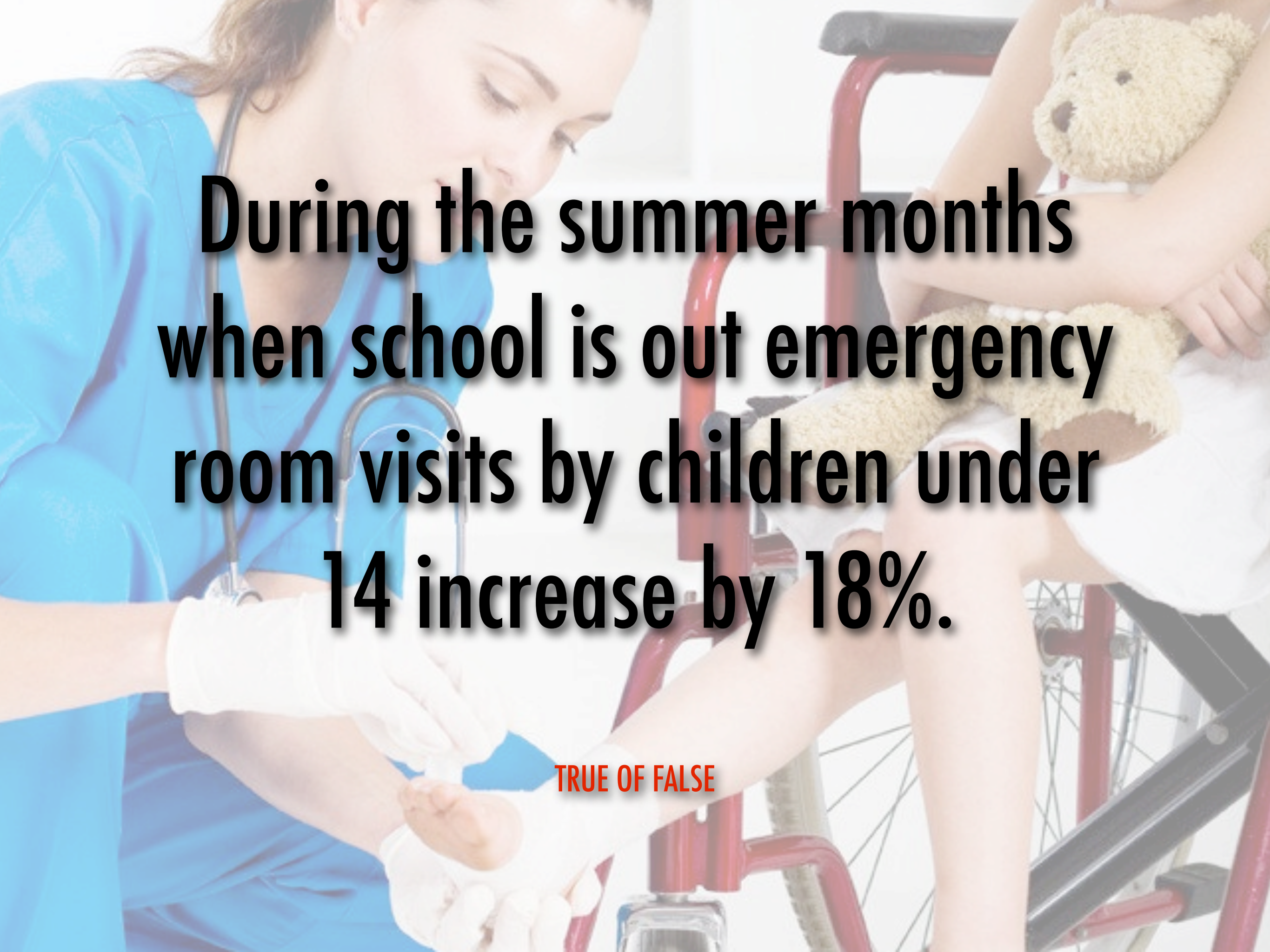
A healthcare worker in blue scrubs and white gloves is examining a child's foot. The child is sitting in a wheelchair and holding a teddy bear. The worker is wearing a stethoscope and has a focused expression. The background is a bright, clinical setting.

**During the summer months
when school is out emergency
room visits by children under
14 increase by 18%.**

TRUE OF FALSE

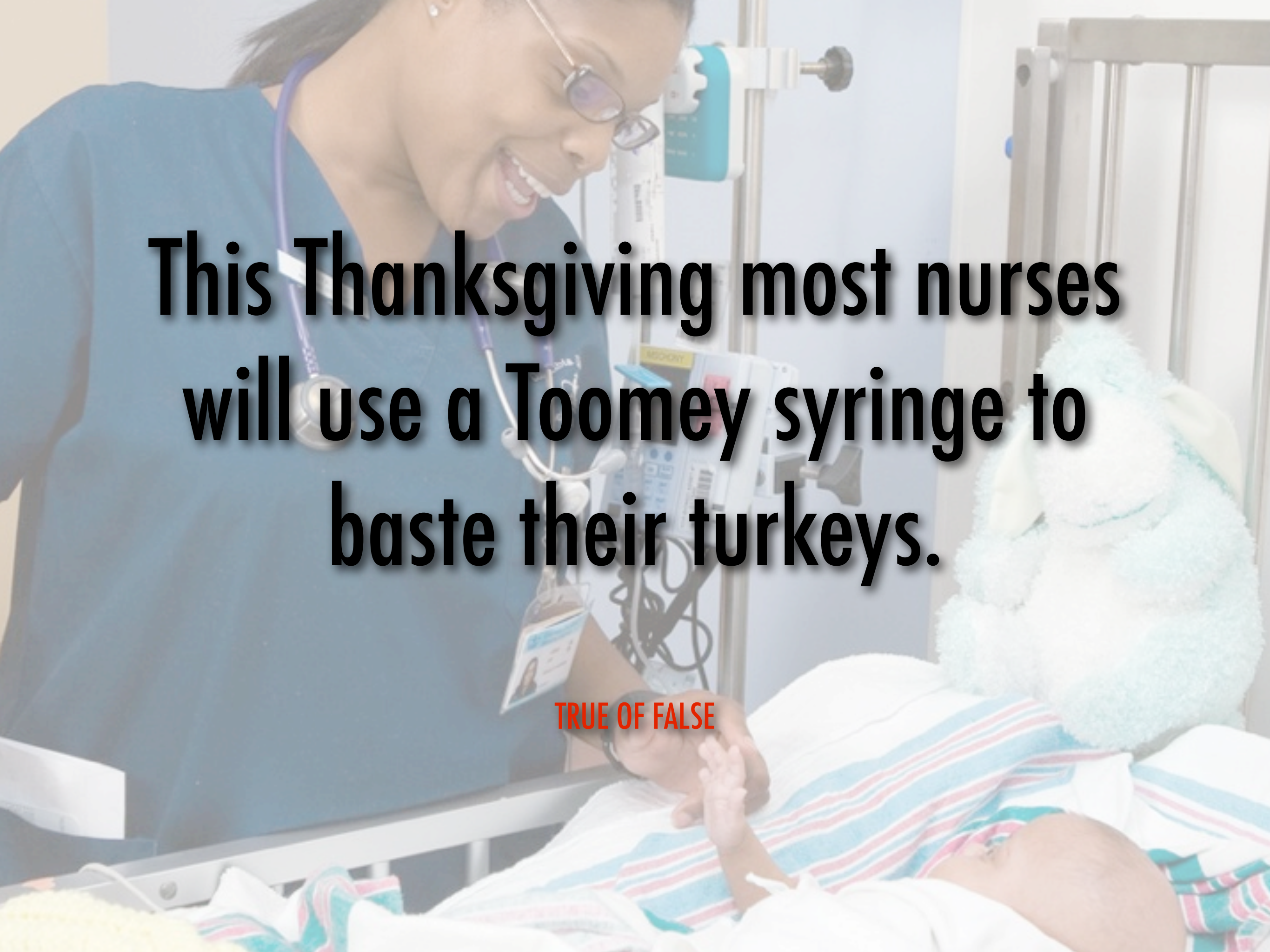

**This Thanksgiving most nurses
will use a Toomey syringe to
baste their turkeys.**

TRUE OF FALSE

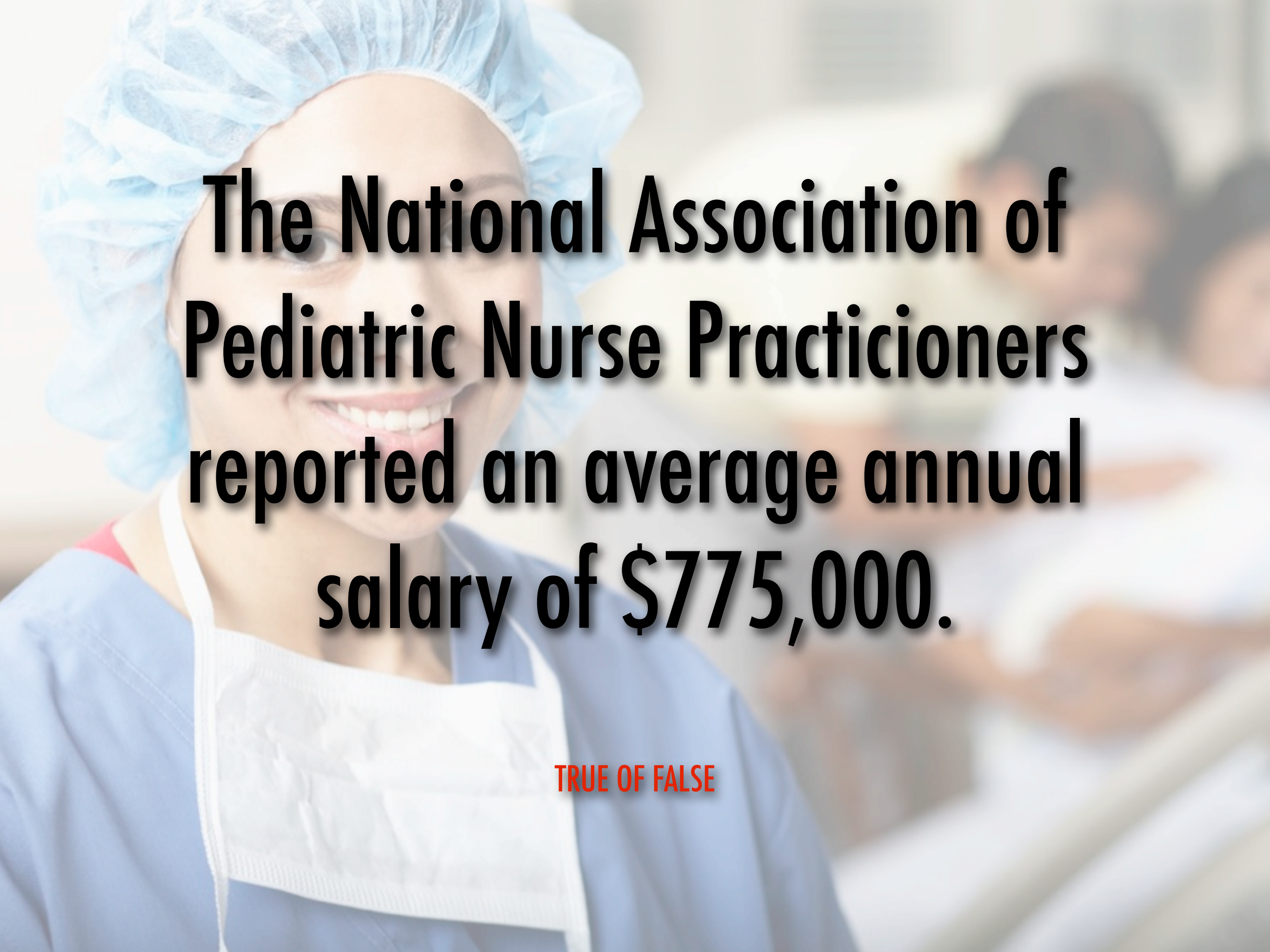

The National Association of Pediatric Nurse Practitioners reported an average annual salary of \$775,000.

TRUE OF FALSE

If you can't explain it simply you
don't understand it well enough.

ALBERT EINSTEIN



"AIGHT"

What can you get everyone to rally around?

People need faith in the future
to gain power in the present.

U N K N O W N



What will nursing look like in the future?



**THE FUTURE
LOOKS LIKE**



WORDS AND PICTURES





Take a minute each day to
remember why we are here, what
we are doing, and how we
are doing it.

J E F F B E Z O S



Ritz Carlton managers huddle with their teams looking for good ideas each shift.



JUST DO IT

Give people a chance to get in the game—ready or not

**The easier something is to do,
the more likely you will do it.**

STEVEN COVEY



TENDENCIES

Work with your natural tendencies



STRENGTHS

People are at their best when they are working at their best

**Don't let what you cannot do
interfere with what you can do.**

J O H N W O O D E N



BRANDED

Brand yourself before someone else does

- **“When dressing for interviews, aim for a neat, professional look. Never wear jeans or flip flops, even if they're decorated flip flops and expensive jeans.”**

—STEPHANIE BRADY, RN, BSN, CPN

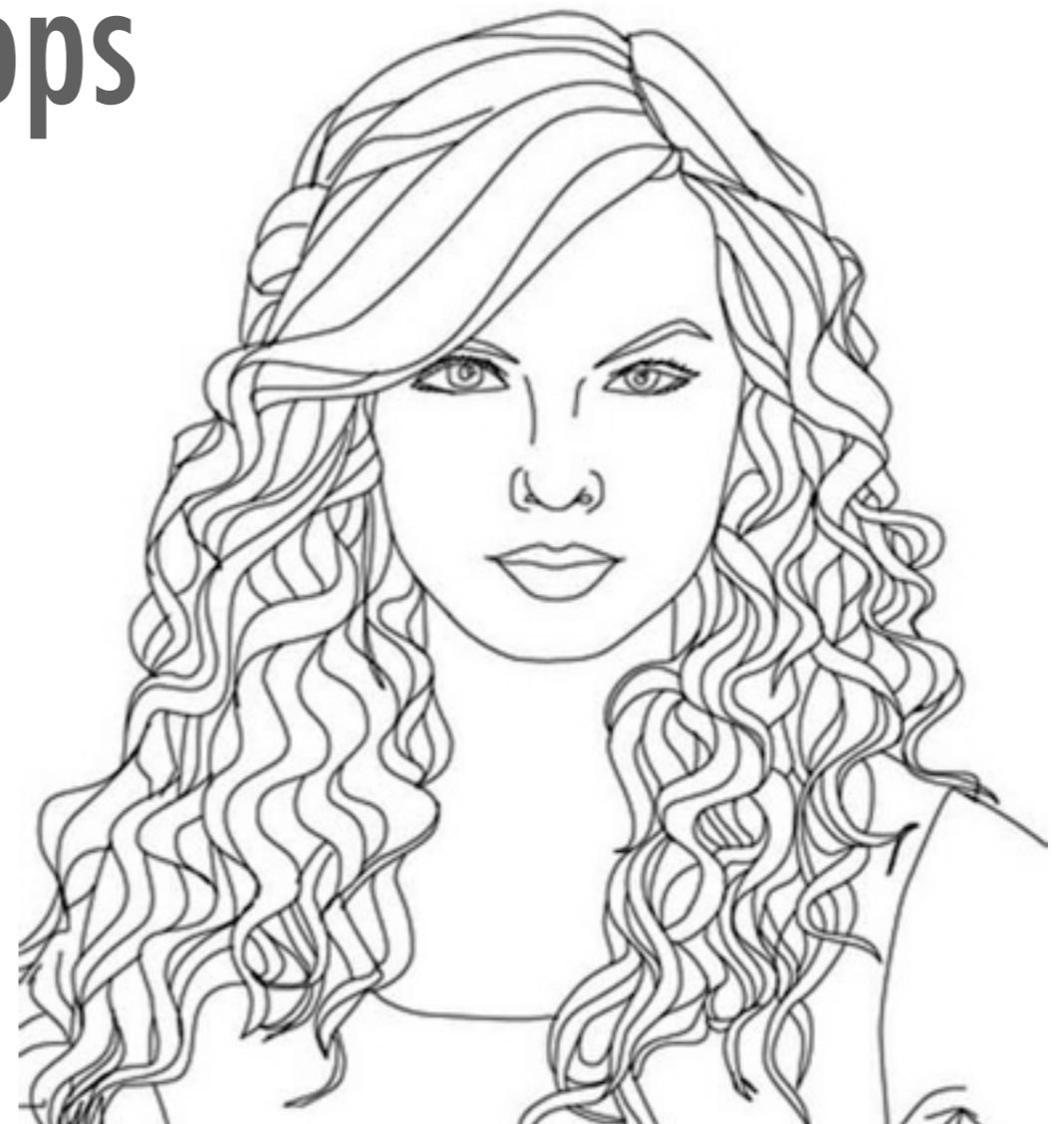



LIVE IT

Check all points of contact to see if you live your brand

- “It’s important we don’t lose sight of the impact we are making and why we do what we do.”

—STEPHANIE BRADY, RN, BSN, CPN



LAST WORDS

What You Do Makes a Difference





THANK YOU

Thank you for being a friend